



8.4 - PERCHAS Y APOYOS PARA SUELO



PERCHA

Para pegar con UVA

Acabados:

Inox brillo	1090 IB
Inox mate	1090 IM

Para vidrio 8/10 mm,
taladro Ø 12 mm

Acabados:

Inox brillo	1091 IB
Inox mate	1091 IM

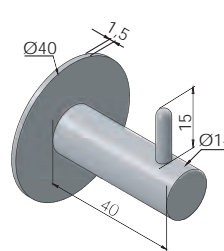

Ref. 1090

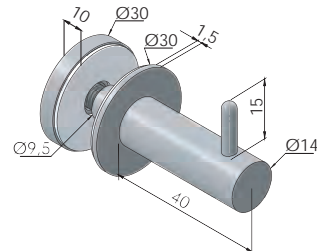

Ref. 1091

3090
3091

PERCHA Q

Para pegar con UVA

Acabados:

Inox brillo	1098 IB
Inox mate	1098 IM

Para vidrio 8/10 mm,
taladro Ø 12 mm

Acabados:

Inox brillo	1099 IB
Inox mate	1099 IM

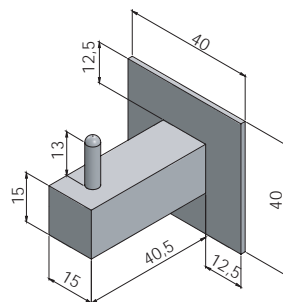

Ref. 1098

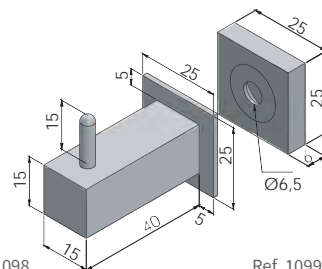

Ref. 1099

3092
3093

APOYO SUELO

Vidrio 8/10 mm

Altura suelo/vidrio: 150 mm

Tubo Ø 20 mm para cortar
a medida

Acabados:

Inox brillo	1092 IB
Inox mate	1092 IM

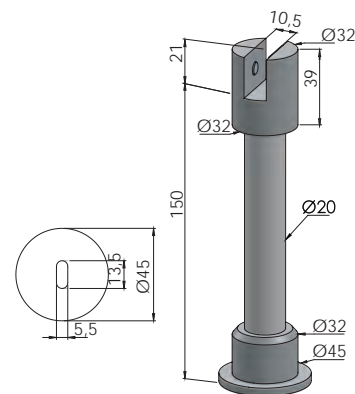

3057

APOYO SUELO REGULABLE

Vidrio 8/10 mm

Altura regulable de 75 a 105 mm

sin cortar el tubo

Acabados:

Inox brillo	1093 IB
Inox mate	1093 IM

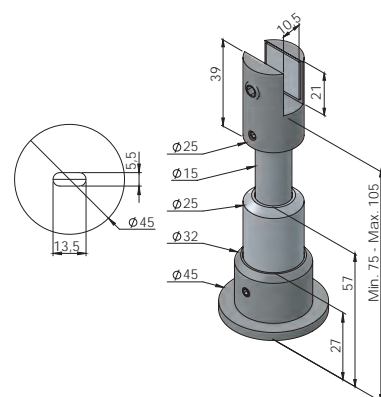

3058

APOYO SUELO Q

Vidrio 8/10 mm
 Altura suelo/vidrio: 150 mm
 Tubo 20 x 20 mm para cortar a medida

Acabados:

Inox brillo	1094 IB
Inox mate	1094 IM

3059

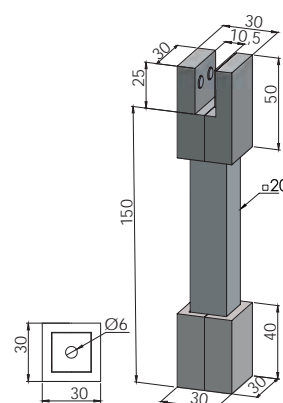

PIE CON PLETINA + PINZA

Vidrio 8/10 mm
 AISI-304

Acabados:

H=60 mm $\nabla = 12$ mm	Inox brillo Inox mate	1920.4 IB 1920.4 IM
H=80 mm $\nabla = 12$ mm	Inox brillo Inox mate	1920.5 IB 1920.5 IM
H=100 mm $\nabla = 12$ mm	Inox brillo Inox mate	1920.6 IB 1920.6 IM

* Grosor especial bajo pedido
 * Con tope bajo pedido

3209
3210
3211

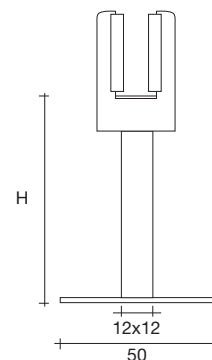

PIE CON PLETINA + PINZA

Vidrio 8/10 mm
 AISI-304

Base ciega

Acabados:

H=60 mm $\nabla = 12$ mm	Inox brillo Inox mate	1920.44 IB 1920.44 IM
H=80 mm $\nabla = 12$ mm	Inox brillo Inox mate	1920.45 IB 1920.45 IM
H=100 mm $\nabla = 12$ mm	Inox brillo Inox mate	1920.46 IB 1920.46 IM

* Grosor especial bajo pedido
 * Con tope bajo pedido

3209C
3210C
3211C

